



◆ FEATURE

- Thin body. Only 2.3mm in maximum thickness.
- Travel is 4mm only.

◆ APPLICATIONS

- For volume control in pocket radio.
- Stereo headphone.

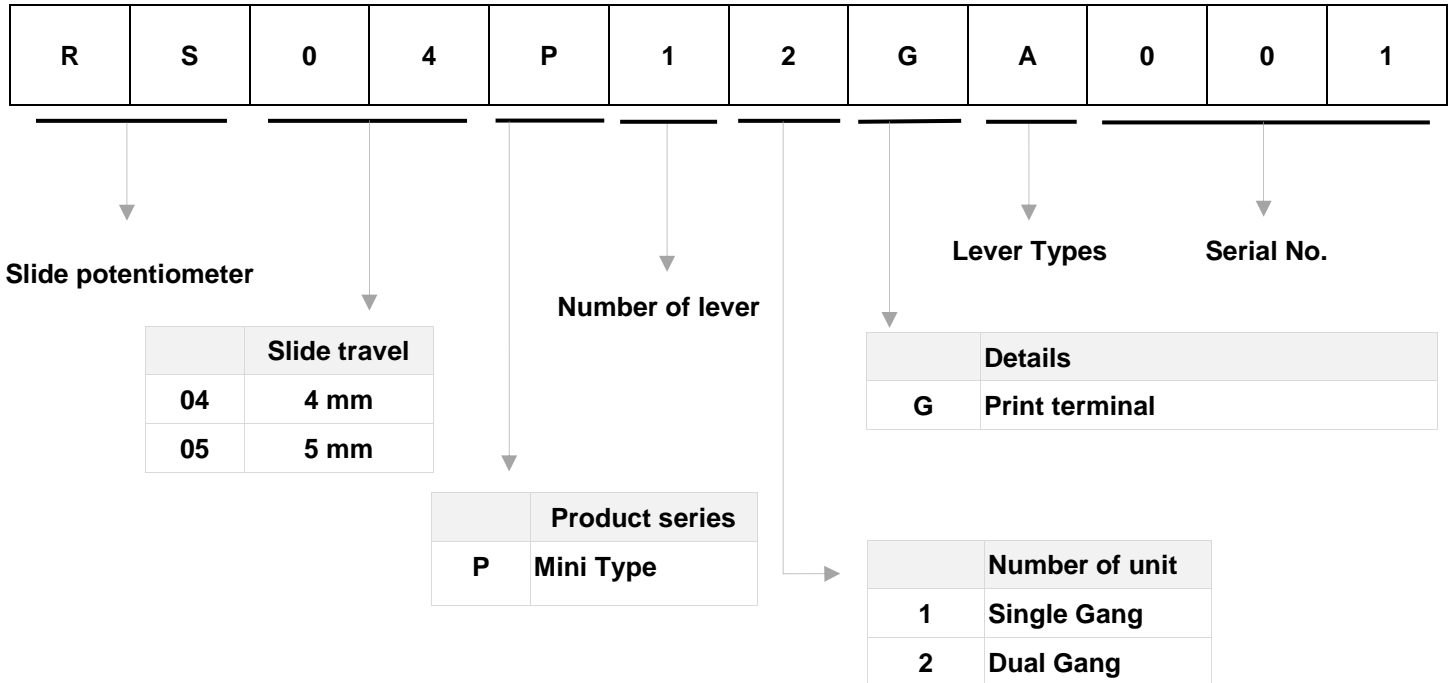

◆ COMMON SPECIFICATIONS

Characteristics	Specification
Operating temperature range	-10°C to +55°C
Operating force	30 ~ 180 gf
Stopper strength	500 gf / 3 sec
Lever push-pull strength	300 gf / 3 sec
Solder heat resistance	Lower than 260°C for less than 5 seconds
Total resistance	500Ω
Total resistance tolerance	±35%
Resistance taper	A,B
Insulation resistance	5MΩ min. 25V DC
Voltage proof	10 sec 25V AC
Sliding service life	5,000 cycles

SLIDE POTENTIOMETER

Mini Type

DIMENSIONS

Unit : mm

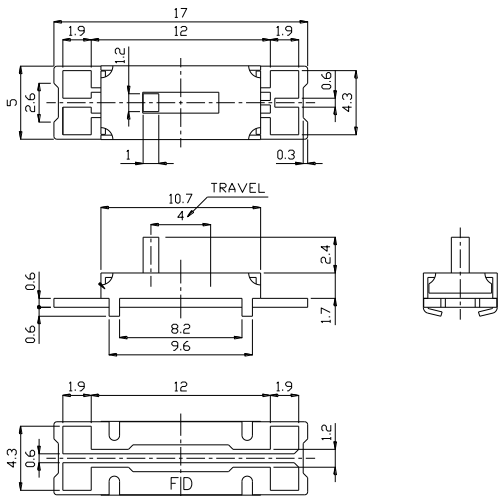
Model	Dimensions
RS04P、RS05P 	RS04P 
	RS05P 